

## RM-94 Schematic Diagrams

<b>Table of Contents</b>	<b>Page No</b>
DCT-4 Common Baseband	2
System Connector, Audio	3
UEMEK, SIM	4
UPP, Combo Memory, IRDA, Bluetooth	5
UI, Vibra, Keyboard	6
RF Part	7
Signal Overview	8
Component Finder	9

DCT-4 Common Baseband

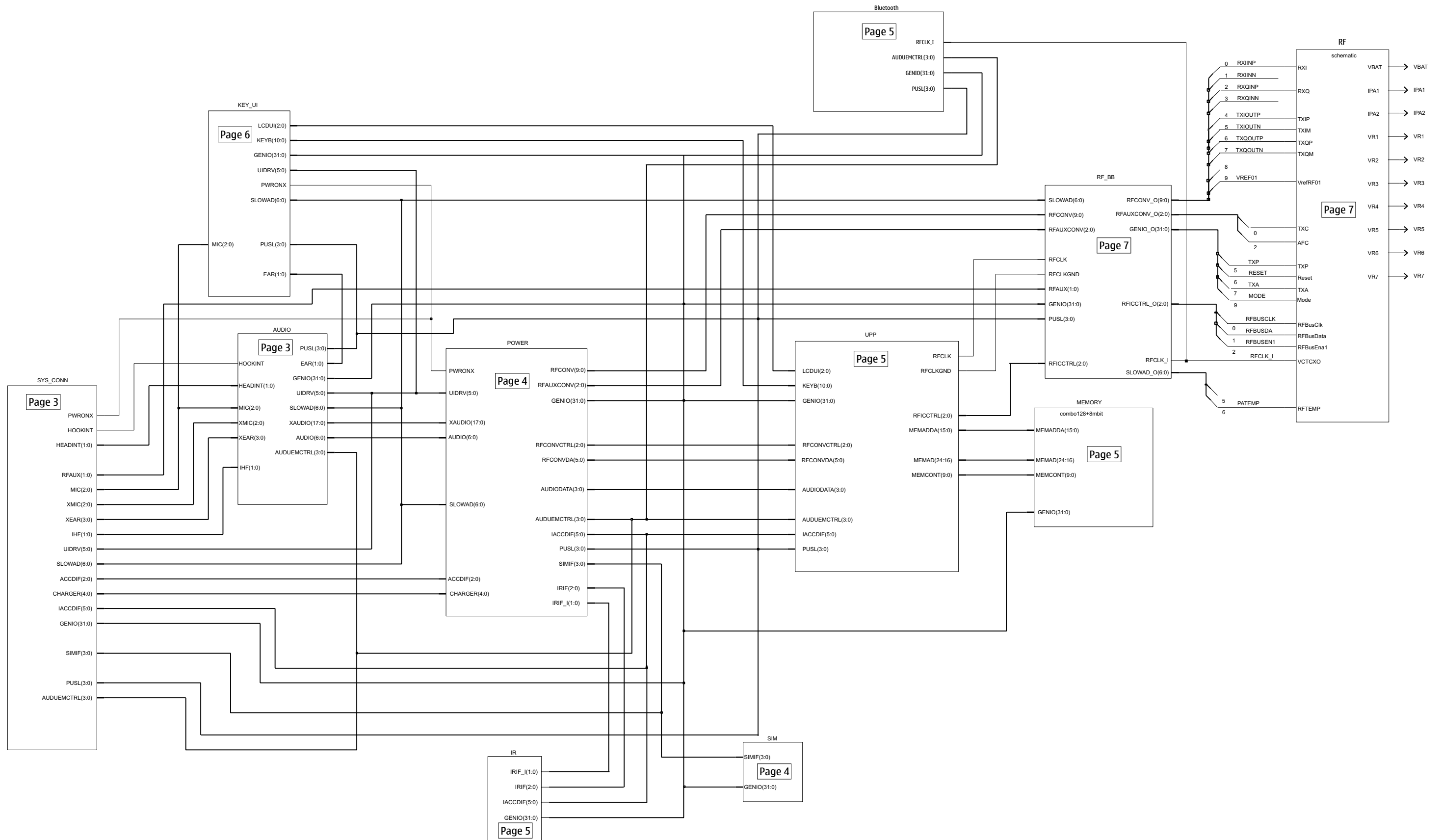

System Connector, Audio

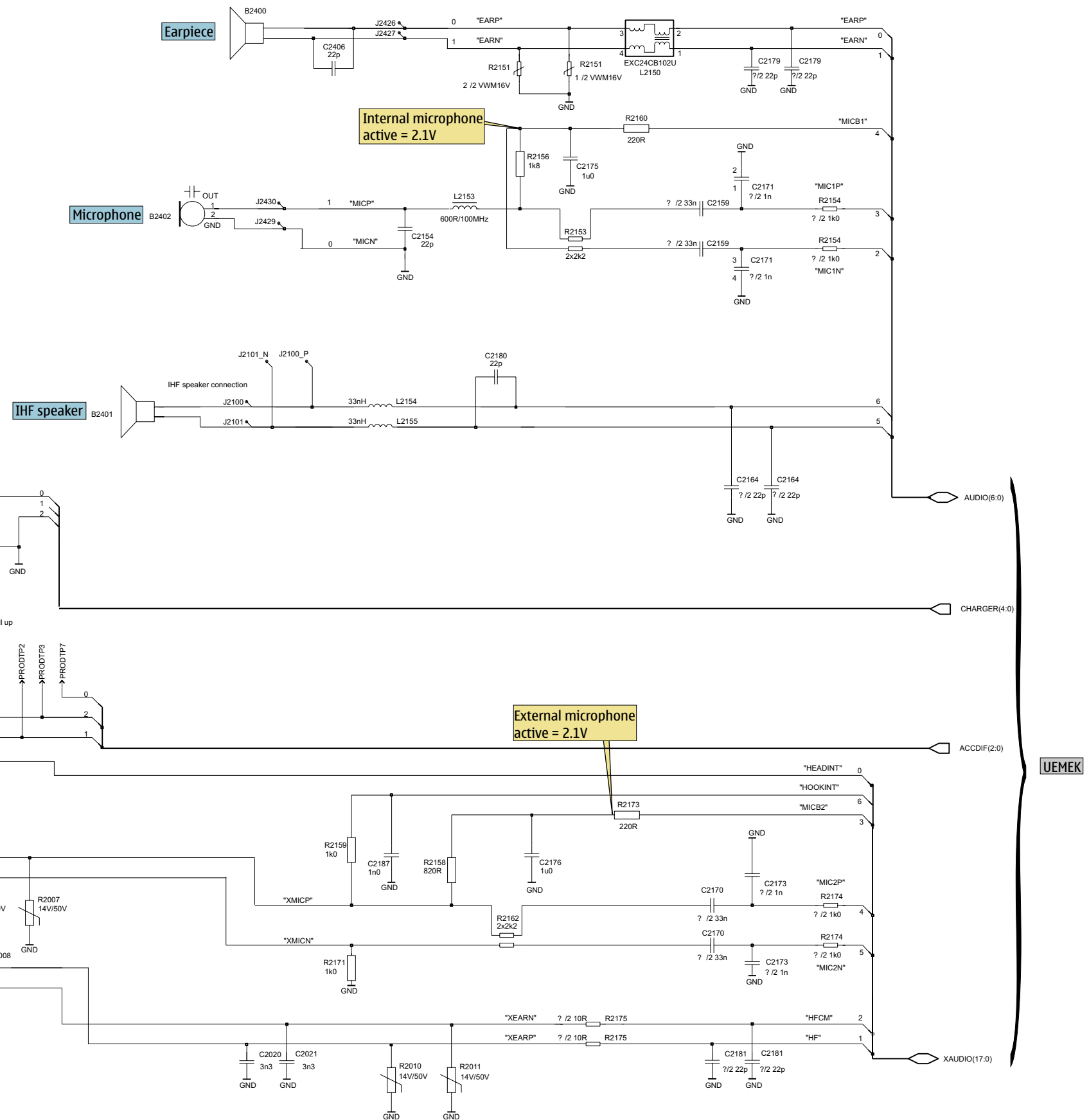
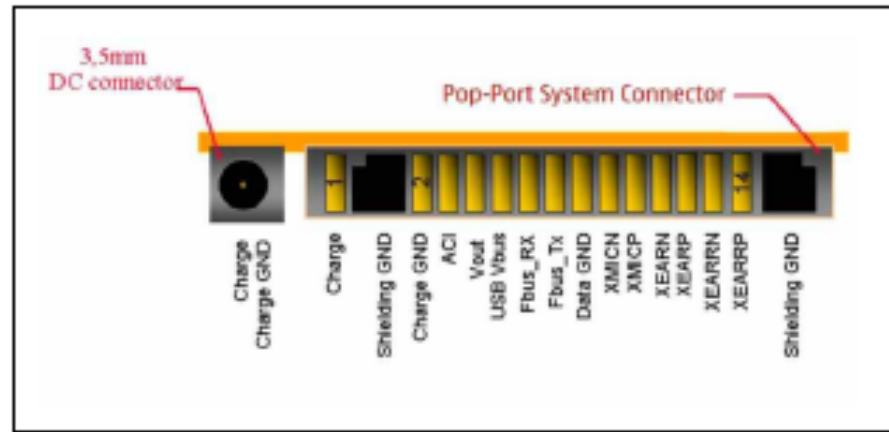

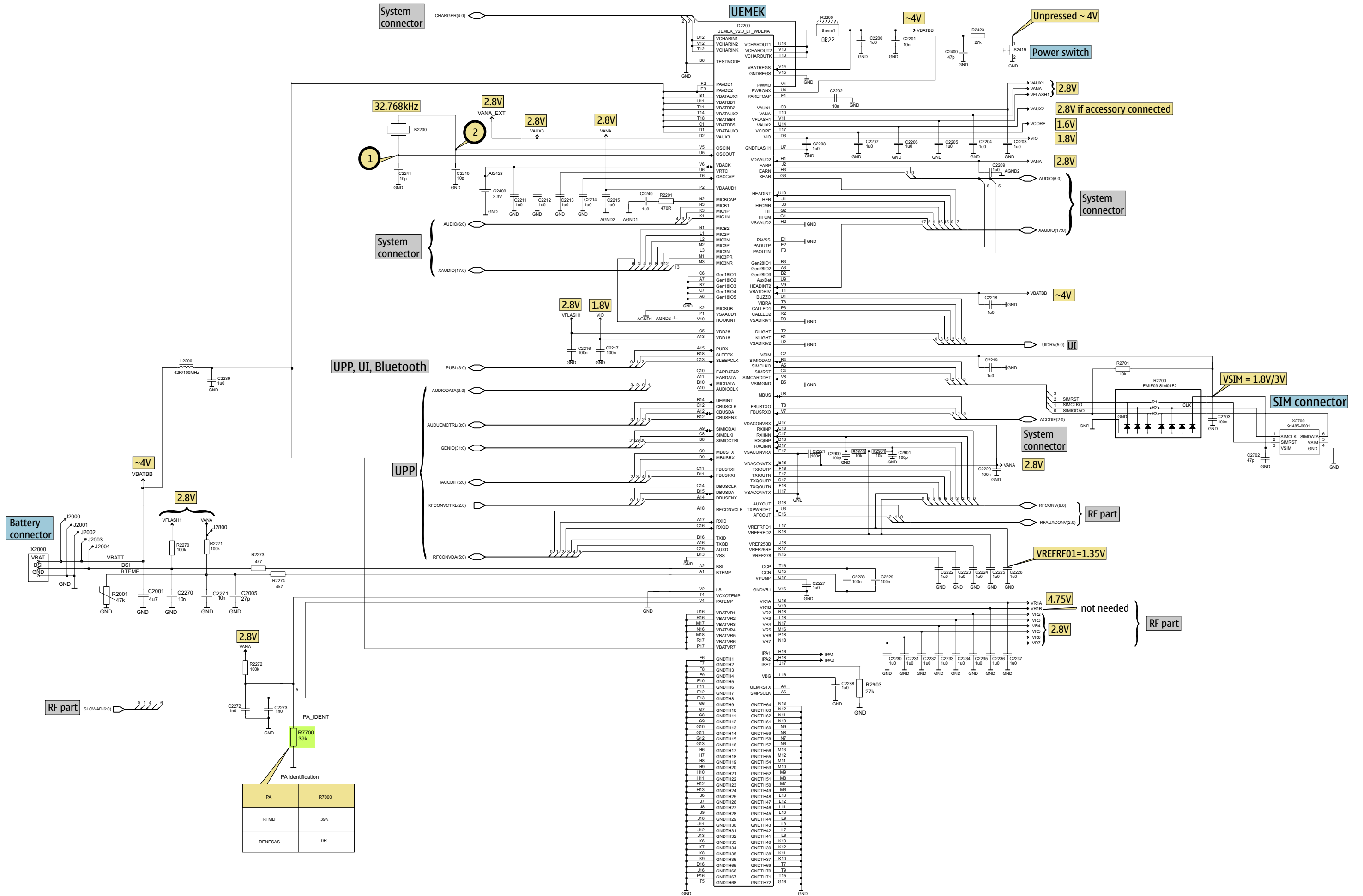

UPP, Combo Memory, IRDA, Bluetooth

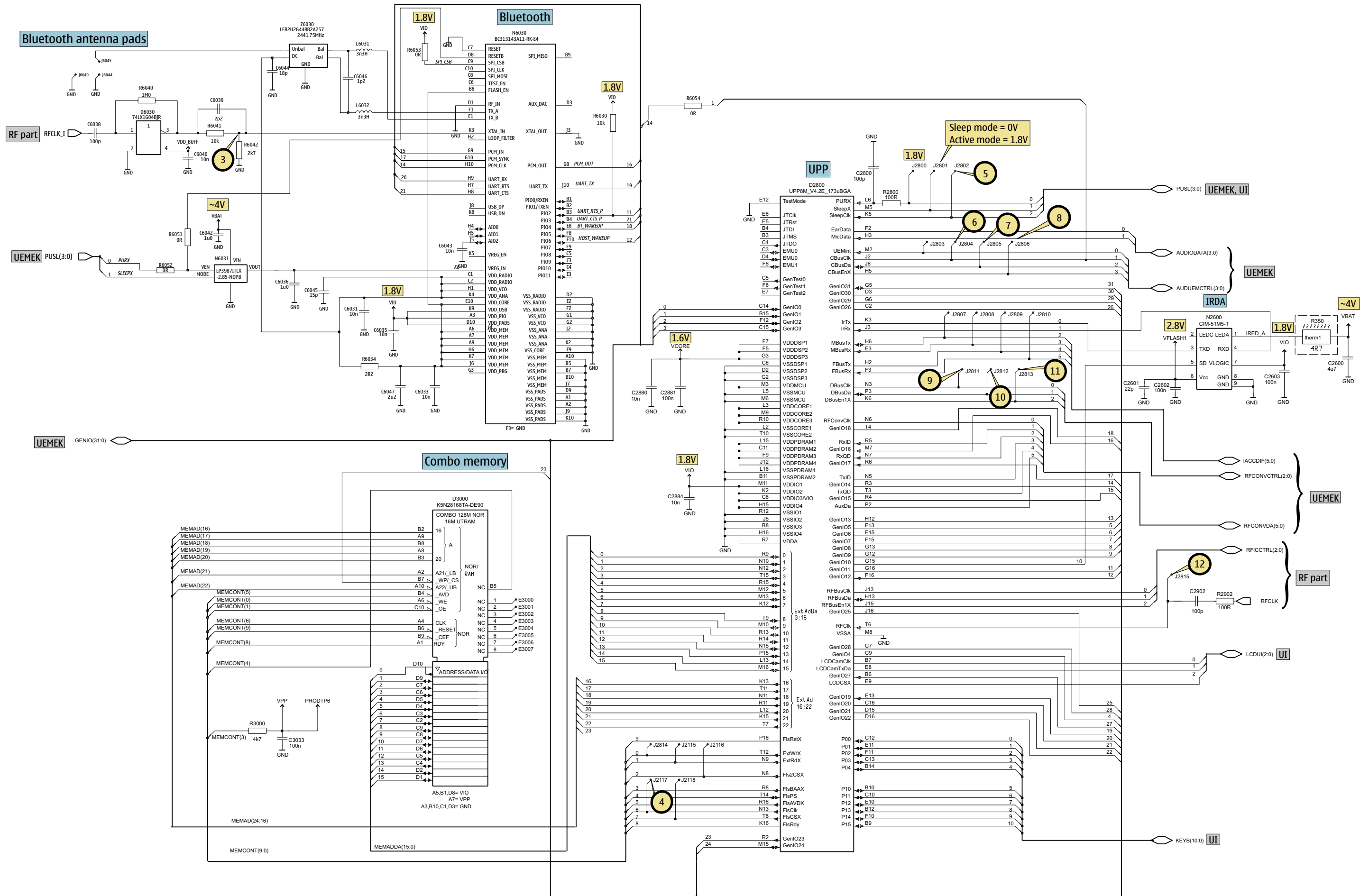

UI, Vibra, Keyboard

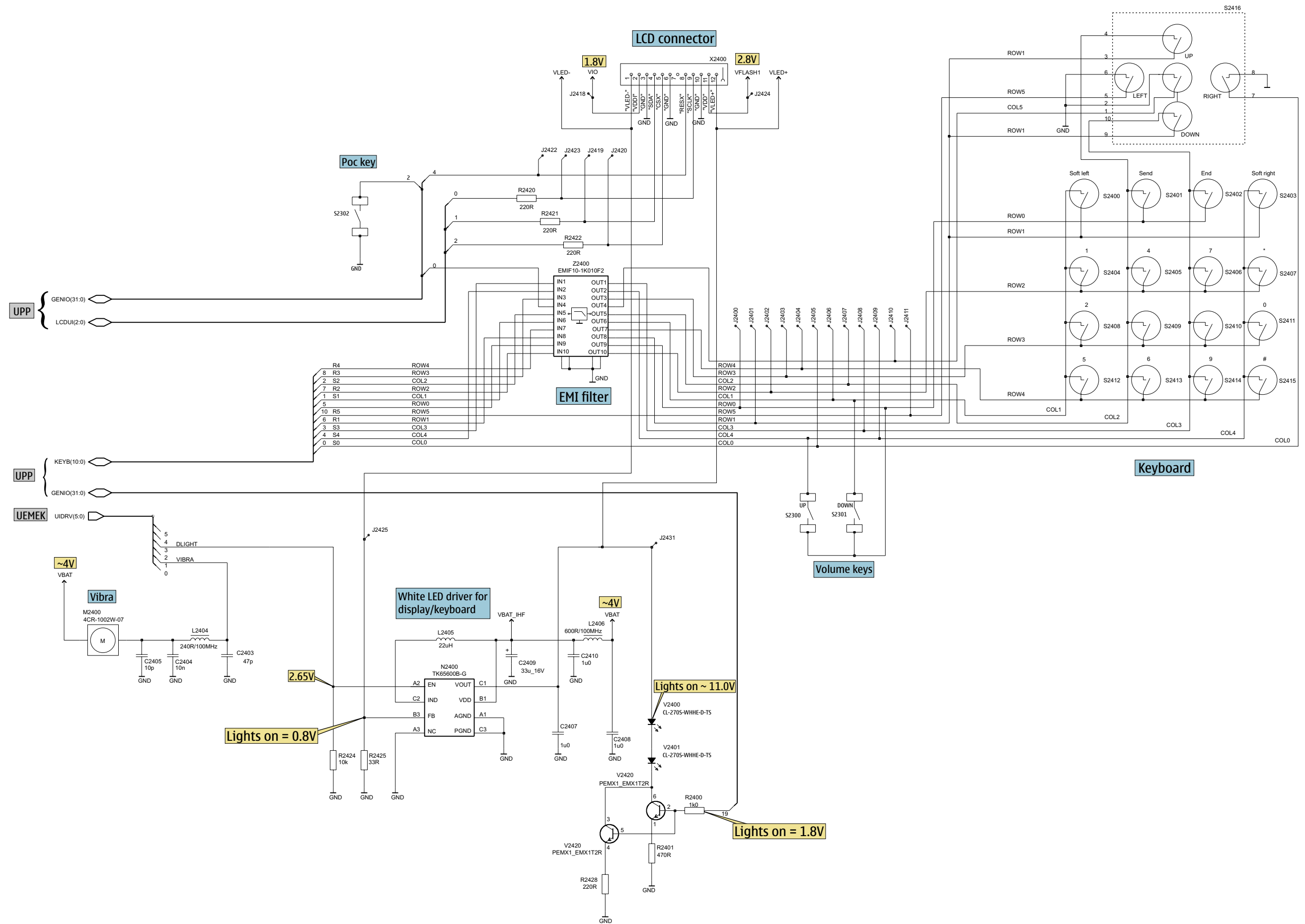

RF Part

VANT_2 VC1 [Volt]	VANT_3 VC2 [Volt]	VANT_1 VC3 [Volt]	RX 1 GSM900 RX	RX 2 GSM1800 RX	RX 3 GSM1900 RX	TX 1 GSM900 TX	TX 2 GSM1800/1900 TX
0	0	0	X				
0	0	0		X			
0	2.6	2.6				X	
0	2.6	0			X		
2.6	2.6	0					X

	N7700	C7701	C7709	C7712	C7716	L7702	R7700	R7701	R7702	R7712	R7713	R7715	R7716	Z7700	
GSM 900 1800/1900	EU BOM1	Renesas PF09015B lib. cut 4.2	100nF	10nF	na	na	22nH	0R	0R	na	1k	100R	100R	1k	FMD B29J V3.1
	EU BOM2	RFMD PA RF9250 ver. 4.1	na	na	10nF	10nF	33nH	39k	1k	4k7	na	33R	33R	na	Murata SX5700B1 SAFEB97MFM0F04
	EU BOM2B	RFMD PA RF9250 ver. 4.1	na	na	10nF	10nF	33nH	39k	1k	4k7	na	33R	33R	na	Murata SX5700B1 SAFEB97MFM0F04
GSM 850 1800/1900	US BOM1	Renesas PF09015B lib. cut 4.2	100nF	10nF	na	na	18nH	0R	0R	na	1k	100R	100R	1k	FMD B29J V3.1
	US BOM2	RFMD PA RF9250 ver. 4.1	1nF	1nF	10nF	10nF	33nH	39k	1k	4k7	na	33R	33R	na	Murata SX5700B1 SAFEB97MFM0F04
	US BOM2B	RFMD PA RF9250 ver. 4.1	na	na	10nF	10nF	33nH	39k	1k	4k7	na	33R	33R	na	Murata SX5700B1 SAFEB97MFM0F04

Band	Channel	RX	VCO/RX	VC/RX	TX	VCO/TX	VC/TX
GSM 850	190	881.6MHz	3526.4MHz	~1.8V	836.6MHz	3346.4MHz	~1.5V
EGSM 900	37	942.4MHz	3769.6MHz	~2.73V	897.4MHz	3589.6MHz	~1.99V
GSM 1800	700	1842.8MHz	3685.6MHz	~2.39V	1747.8MHz	3495.6MHz	~1.60V
GSM 1900	661	1960.0MHz	3920.0MHz	~3.31V	1880.0MHz	3760.0MHz	~2.96V

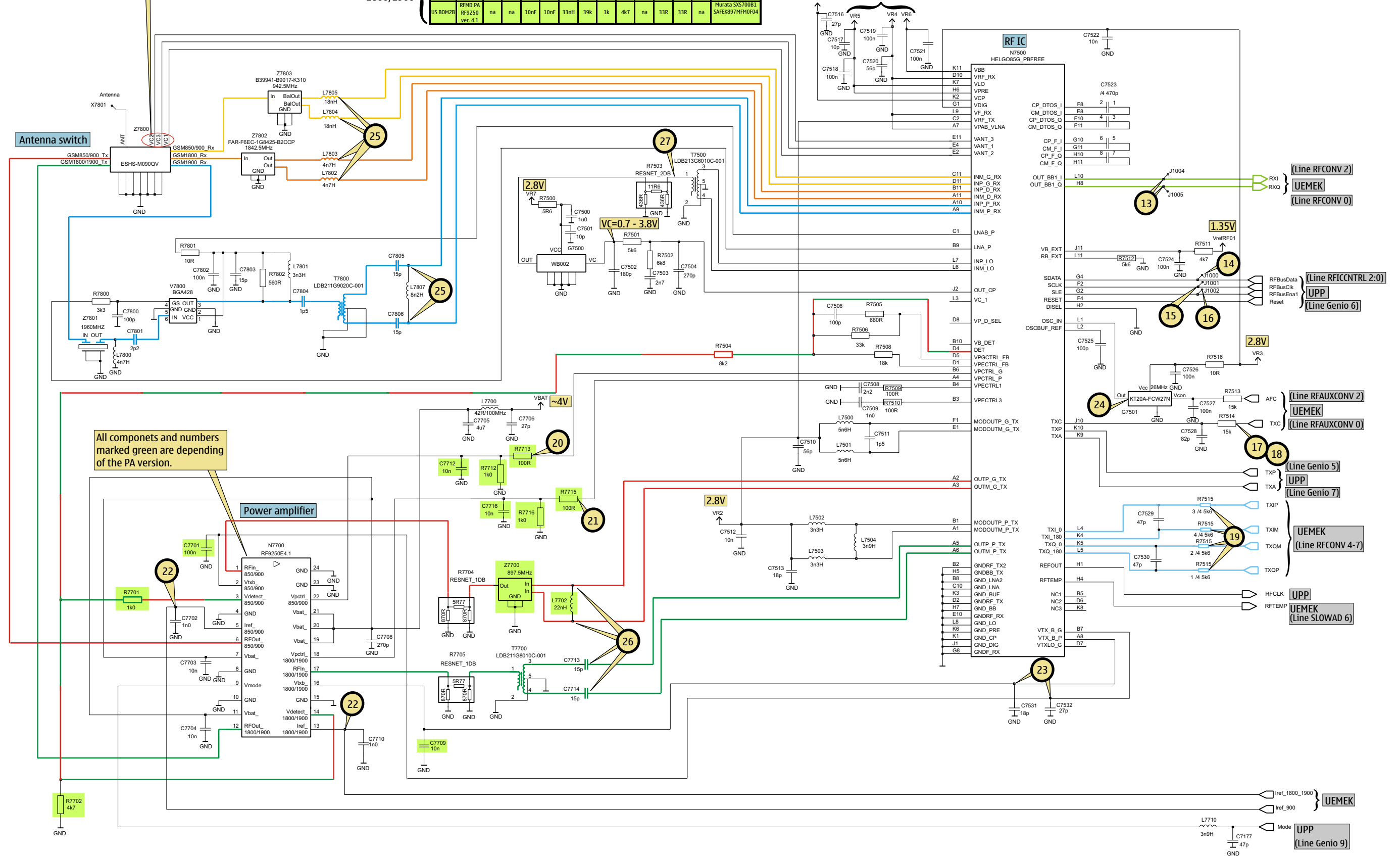

Signal Overview

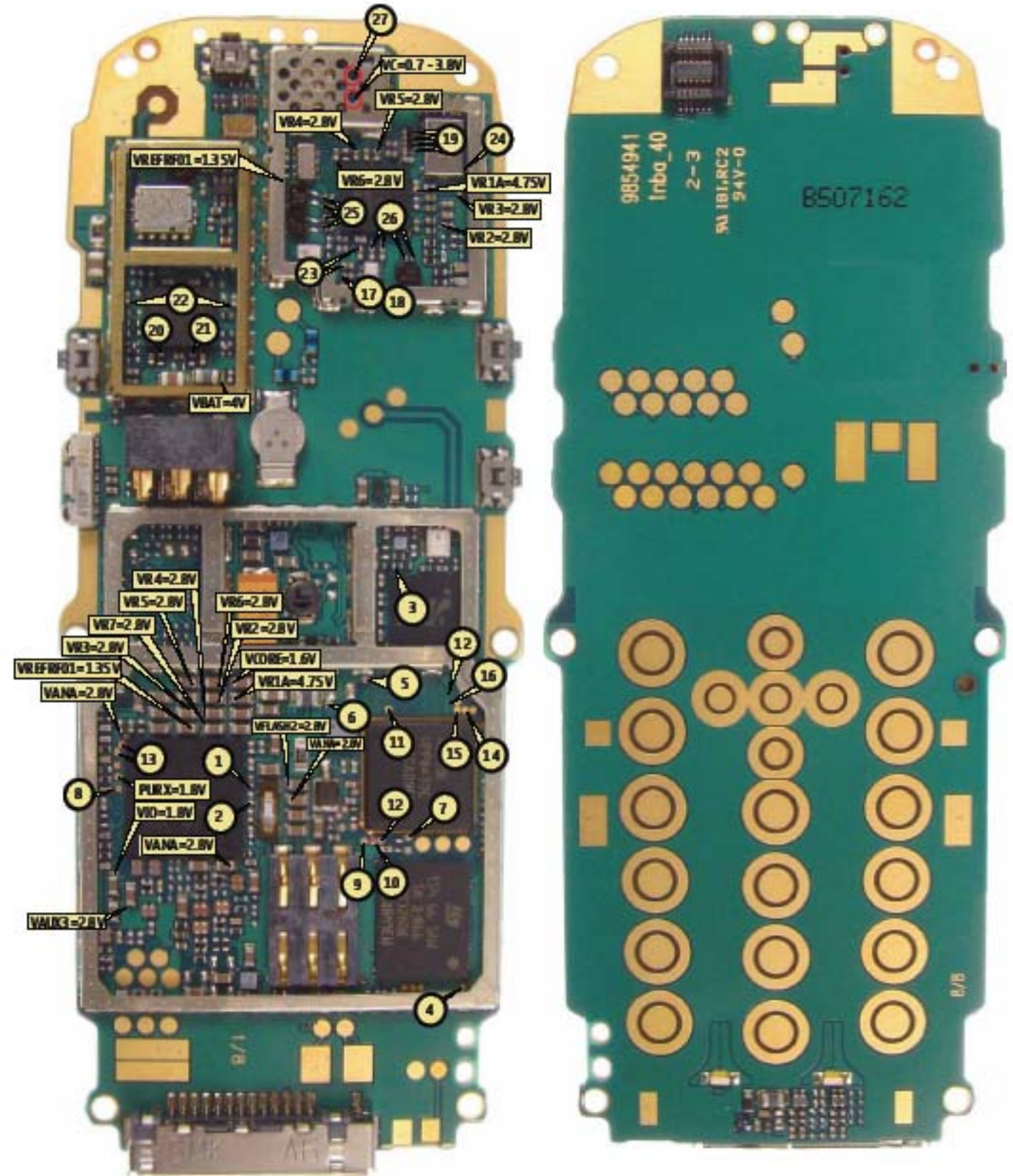
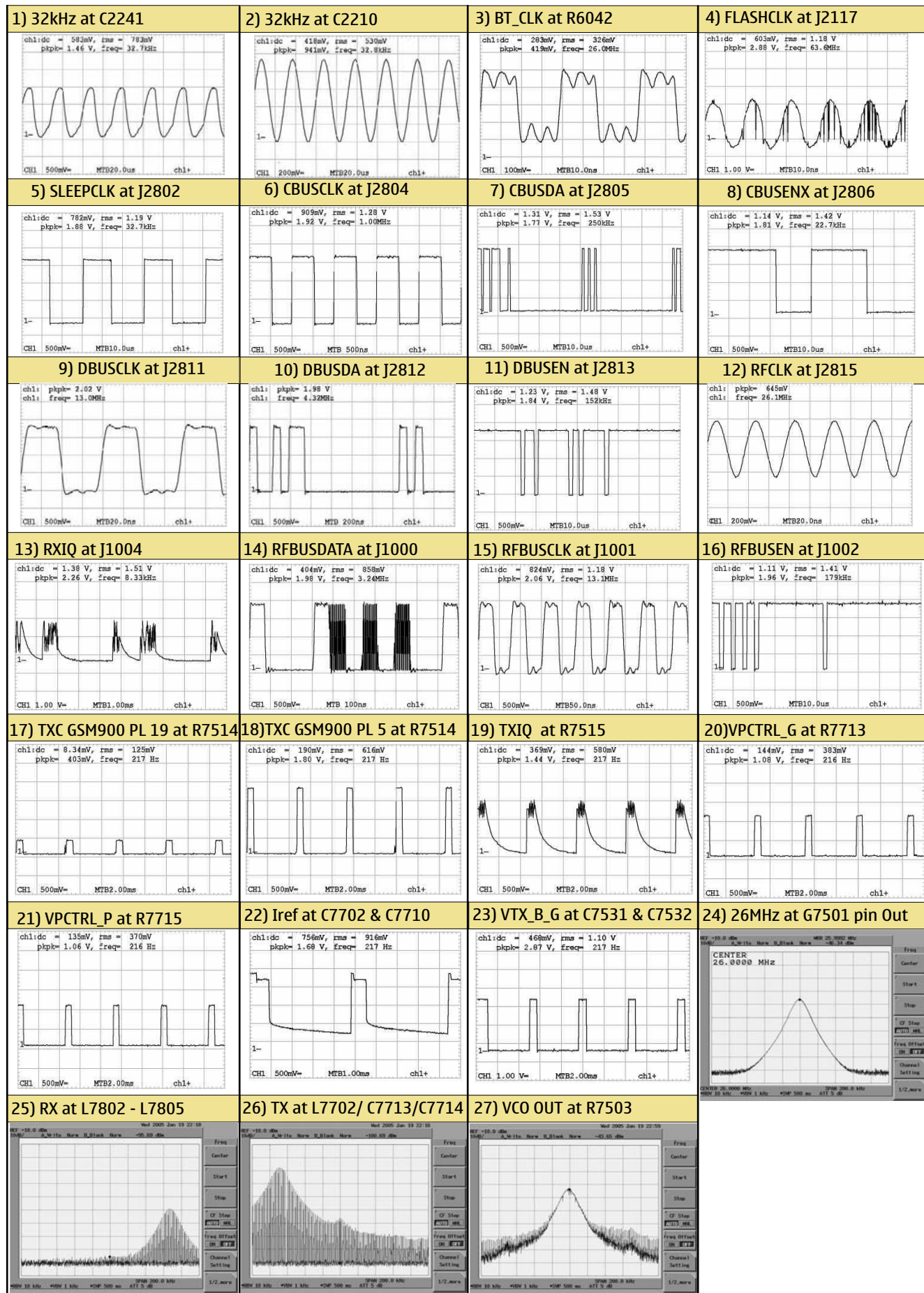



Component Finder

B	C2241	O4	C7527	C7	N	R7503	C6		
B2200	05	C2270	02	C7529	D7	N2400	K5	R7504	E7
C	C2271	P2	C7530	D7	N2600	J1	R7505	F7	
C2001	M5	C2272	N2	C7531	F6	N6030	L7	R7506	F7
C2005	P6	C2273	P4	C7532	F6	N6031	J6	R7508	E8
C2006	U5	C2400	P4	C7533	F7	N7500	E6	R7509	F7
C2007	O4	C2401	P4	C7702	G2	N7700	G3	R7510	F7
C2008	U5	C2403	Q3	C7703	F3	R	R7511	D5	
C2009	Q2	C2404	R2	C7704	F3	R2000	U6	R7512	D6
C2011	R2	C2405	R2	C7705	H3	R2001	O6	R7513	C7
C2012	U5	C2406	C4	C7706	H4	R2002	R2	R7514	F6
C2013	U5	C2407	K5	C7708	H3	R2003	R2	R7515	D7
C2020	U4	C2408	J4	C7709	G4	R2004	R3	R7516	E8
C2021	U4	C2409	L4	C7710	G4	R2005	R2	R7700	N2
C2154	R3	C2410	K4	C7712	H3	R2006	U5	R7701	G2
C2159	Q3	C2600	F2	C7713	F6	R2007	U5	R7702	G4
C2164	P2	C2601	J2	C7714	F6	R2010	U4	R7704	G2
C2170	Q4	C2602	J2	C7716	H3	R2011	U4	R7705	G4
C2171	Q3	C2603	J2	C7800	D4	R2151	C4	R7710	H2
C2173	Q4	C2702	R6	C7801	D3	R2153	R3	R7712	H3
C2175	R3	C2703	R6	C7802	E3	R2154	Q3	R7713	H3
C2176	R4	C2800	O6	C7803	E4	R2156	R3	R7715	H3
C2179	Q3	C2880	O6	C7804	F4	R2158	R4	R7716	H3
C2180	H5	C2881	O6	C7805	F6	R2159	Q4	R7800	D4
C2181	P3	C2884	O6	C7806	F6	R2160	Q3	R7801	E4
C2187	Q4	C2900	N2	D	R2162	Q4	R7802	E4	
C2200	O5	C2901	N2	D2200	O3	R2171	R4	S	
C2201	N4	C2902	O8	D2800	O7	R2173	Q4	S2300	G8
C2202	Q3	C3033	P7	D3000	Q7	R2174	P4	S2301	J8
C2203	Q2	C3180	P8	D6030	K7	R2175	Q3	S2302	H1
C2204	O5	C6031	K8	F	R2200	N5	S2419	B4	
C2205	O5	C6033	K6	F2000	U5	R2201	P3	T	
C2206	N5	C6035	L6	G	R2270	O2	T7500	C6	
C2207	M4	C6036	J7	G2400	I5	R2271	O2	T7700	F6
C2208	Q2	C6038	K7	G7500	C5	R2272	O2	T7800	F5
C2209	Q3	C6039	K7	G7501	D8	R2273	P2	V	
C2210	O4	C6040	J7	L	R2274	P2	V2000	O6	
C2211	P5	C6042	J6	L2000	T5	R2400	M6	V2400	T4
C2212	Q2	C6043	L6	L2001	T4	R2401	L5	V2401	T6
C2213	O5	C6044	K7	L2003	T5	R2420	L6	V2420	L5
C2214	P5	C6045	L6	L2004	U5	R2421	L6	V7800	E4
C2215	P4	C6046	K8	L2005	U5	R2422	L6	X	
C2216	P2	C6047	K6	L2150	C4	R2423	C4	X2000	I3
C2217	O2	C7177	H2	L2153	Q3	R2424	J5	X2002	U4
C2218	Q4	C7500	C5	L2154	H5	R2425	J5	X2060	C4
C2219	R4	C7501	B5	L2155	G5	R2428	L6	X2400	C6
C2220	N2	C7502	B6	L2200	M5	R2600	E2	X2700	Q5
C2221	N2	C7503	B6	L2404	R2	R2700	R4	Z	
C2222	M3	C7504	C6	L2405	L5	R2701	S4	Z2400	N6
C2223	N3	C7506	F8	L2406	K4	R2800	O6	Z6030	K7
C2224	N3	C7508	F8	L6031	K8	R2900	N2	Z7700	F7
C2225	M2	C7509	F8	L6032	K7	R2901	N2	Z7800	E3
C2226	N3	C7510	E8	L7500	E7	R2902	O8	Z7801	D3
C2227	N4	C7511	E7	L7501	E7	R2903	N2	Z7802	E5
C2228	N4	C7512	E8	L7502	E7	R3000	P7	Z7803	E5
C2229	N4	C7513	E8	L7503	E7	R3180	P8		
C2230	N4	C7516	D7	L7504	E7	R6030	M8		
C2231	M4	C7517	D6	L7700	H3	R6034	K7		
C2232	M3	C7518	D6	L7702	F7	R6040	K7		
C2233	N4	C7519	D6	L7710	H2	R6041	K7		
C2234	N3	C7520	E6	L7800	D3	R6042	K7		
C2235	M4	C7521	D6	L7801	E4	R6052	J7		
C2236	N4	C7522	D7	L7802	E6	R6053	M7		
C2237	M4	C7523	D5	L7803	E6	R6054	M6		
C2238	M3	C7524	D5	L7804	E6	R7500	C5		
C2239	N5	C7525	D7	L7805	E6	R7501	C6		
C2240	P3	C7526	C8	L7807	E6	R7502	B6		

